

Hopper Barge 489 m³

Main Specifications

Length over all	35.54 m
Breadth over all	9.05 m
Depth	2.64 m
Free board	0.07 m
Air draught	4.22 m
Draught unloaded	0.52 m
Draught loaded	2.57 m
Loading capacity	602 tonnes

Hopper hold

Volume	489 m ³
Length	27.91 m
Breadth on coaming	7.05 m
Breadth on floor	4.06 m

Particulars

Hopper Barge no.	B51, B53 (2 no.)
Built	1983 / adjusted 2001
Inland classification	NSI (CvO/CBB)
	Zone 2 (NL), 3, 4 + Rhine
Certificate	Port of London Authority
Weight	240 tonnes

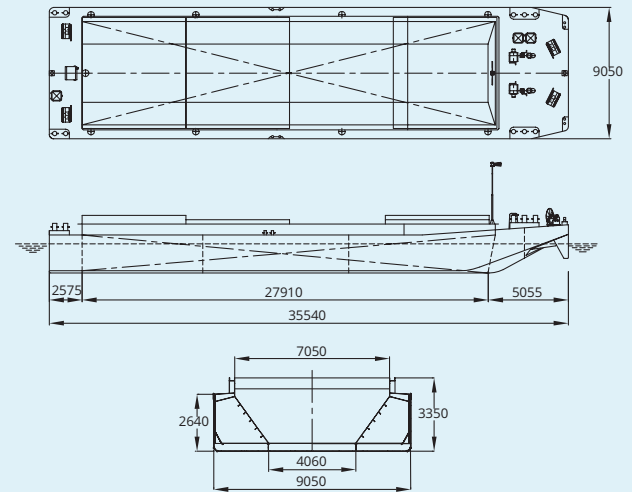

Hopper Barge 697 m³

Main Specifications

Length over all	54.92 m
Breadth over all	9.02 m
Depth	2.62 m
Free board	0.07 m
Air draught	4.25 m
Draught unloaded	0.56 m
Draught loaded	2.55 m
Loading capacity	847 tonnes

Hopper hold

Volume	697 m ³
Length	39.92 m
Breadth on coaming	7.07 m
Breadth on floor	4.00 m

Particulars

Hopper Barge no.	B75
Built	1984 / adjusted 2002
Inland classification	NSI (CvO/CBB)
	Zone 2 (NL), 3, 4 + Rhine
Weight	225 tonnes

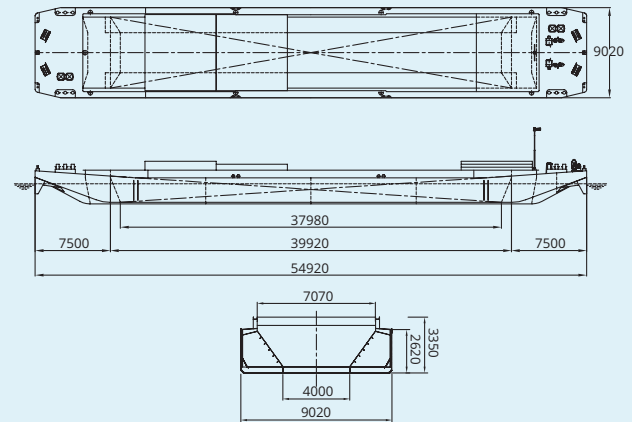

Hopper Barge 881 m³

Main Specifications

Length over all	64.25 m
Breadth over all	9.02 m
Depth	2.62 m
Free board	0.07 m
Air draught	4.26 m
Draught unloaded	0.54 m
Draught loaded	2.55 m
Loading capacity	1057 tonnes

Hopper hold

Volume	881 m ³
Length	49.91 m
Breadth on coaming	7.05 m
Breadth on floor	4.06 m

Particulars

Hopper Barge no.	B80 - B83 (4 no.)
Built	1983 / adjusted 2001 1985 / adjusted 2002
Inland classification	NSI (CvO/CBB) Zone 2 (NL), 3, 4 + Rhine
Certificate	Port of London Authority
Weight	255 tonnes

